

# SERIE LADY - Mod. 275 S CEV



Affilatoio fisso.  
Fixed sharpener.



Pressamerce con protezione in plexiglass.  
Food-holder arm with protection in plexiglass.

## Caratteristiche

- Basamento in alluminio fuso con ossidazione anodica lucida.
- Coprilama e piatto in alluminio fuso con ossidazione anodica lucida.
- Albero portalama montato su doppio cuscinetto a sfere.
- Motore professionale ventilato.
- Lama professionale, temperata, rettificata e cromata a cromo duro.
- Anello fisso di protezione della lama.
- Pressamerce in alluminio protetto con ossidazione anodica.
- Vela in alluminio fuso con ossidazione anodica lucida.
- Spessore di taglio fino a 14 ÷ 16 mm.

## Features

- Base in cast aluminium with polished anodic oxidation.
- Blade cover and food tray in cast aluminium with polished anodic oxidation.
- Shaft holding the blade mounted on a double ball-bearing.
- Professional ventilated motor.
- Professional tempered ground hard chromium-plated blade.
- Fixed blade protection ring.
- Food holder arm in anodized aluminium.
- Sail-shaped rest in cast aluminium with polished anodic oxidation.
- Slicing thickness up to 14 ÷ 16 mm.



Manopola graduata ed interruttore per centralina CEV.  
Graduated knob and switch linked to CEV control unit.

## DIMENSIONI - DIMENSIONS

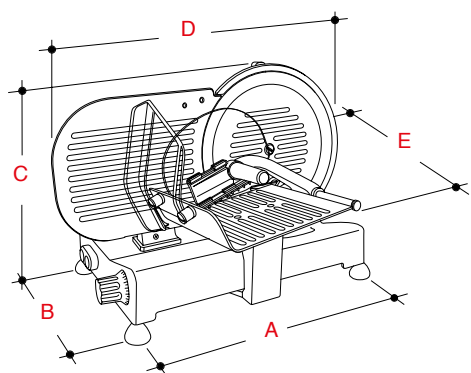

A	B	C	D	E
mm	mm	mm	mm	mm
415	263	375	505	410

SERIE LADY	Diametro lama Blade diameter	Potenza motore Power	Capacità di taglio Cutting capacity	N° giri lama Saw blade speed	Corsa carrello Trolley run	Peso netto Net weight	imballo Packing
	mm	Watt	±5 mm	g/min. (RPM)	mm	Kg	cm
<b>MOD 275 S CEV</b>	275	150	230 x 190	320	255	16,5	51x62x47 (0,15m³)